

Technical data sheet

Product features



Electric range with static oven

Model	SAP Code	00014786
--------------	-----------------	----------



- Device type: Electric unit
- Power consumption of the zone 1 [kW]: 2,6
- Power consumption of the zone 2 [kW]: 2,6
- Power consumption of the zone 3 [kW]: 2,6
- Power consumption of the zone 4 [kW]: 2,6
- Power consumption of the zone 5 [kW]: 2,6
- Power consumption of the zone 6 [kW]: 2,6
- Type of internal part of the appliance 1 (eg oven): Electric
- Type of internal part of the appliance 2 (eg oven): Static
- Protection of controls: IP24
- Material: AISI 304 top plate and cladding

SAP Code	00014786	Power consumption of the zone 1 [kW]	2,6
Net Width [mm]	1200	Power consumption of the zone 2 [kW]	2,6
Net Depth [mm]	730	Power consumption of the zone 3 [kW]	2,6
Net Height [mm]	900	Power consumption of the zone 4 [kW]	2,6
Net Weight [kg]	126.00	Power consumption of the zone 5 [kW]	2,6
Power electric [kW]	21.900	Power consumption of the zone 6 [kW]	2,6
Loading	400 V / 3N - 50 Hz	Type of internal part of the appliance 1 (eg oven)	Electric
Number of zones	6	Type of internal part of the appliance 2 (eg oven)	Static

Technical data sheet

Technical drawing



Electric range with static oven

Model

SAP Code

00014786

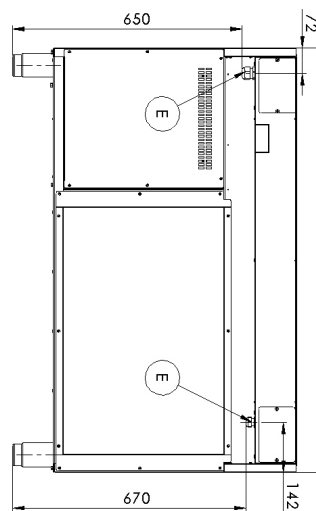
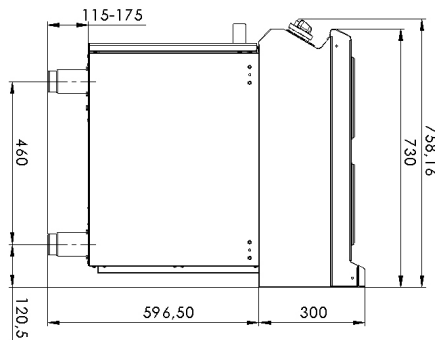
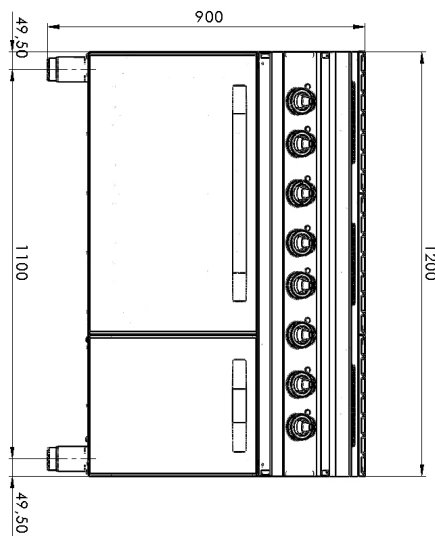

Technical data sheet

Technical parameters



Electric range with static oven

Model

SAP Code

00014786

1. SAP Code:

00014786

2. Net Width [mm]:

1200

3. Net Depth [mm]:

730

4. Net Height [mm]:

900

5. Net Weight [kg]:

126.00

6. Gross Width [mm]:

1260

7. Gross depth [mm]:

820

8. Gross Height [mm]:

1080

9. Gross Weight [kg]:

142.00

10. Device type:

Electric unit

11. Construction type of device:

Stationary

12. Power electric [kW]:

21.900

13. Loading:

400 V / 3N - 50 Hz

14. Protection of controls:

IP24

15. Exterior color of the device:

Stainless steel

16. Material:

AISI 304 top plate and cladding

17. Indicators:

operation

18. Worktop type:

Molded - comfortable cleaning maintenance

19. Worktop material:

AISI 304

20. Worktop Thickness [mm]:

1.50

21. Number of zones:

6

22. Power consumption of the zone 1 [kW]:

2,6

23. Power consumption of the zone 2 [kW]:

2,6

24. Power consumption of the zone 3 [kW]:

2,6

25. Power consumption of the zone 4 [kW]:

2,6

26. Power consumption of the zone 5 [kW]:

2,6

27. Power consumption of the zone 6 [kW]:

2,6

28. Maximum device temperature [°C]:

300

Technical data sheet

Technical parameters



Electric range with static oven

Model

SAP Code

00014786

29. Minimum device temperature [°C]:

50

30. Service accessibility:

Trough the frontal panel

31. Adjustable feet:

Yes

32. Number of burners/hot plates:

6

33. Type of electric cooking zones:

Oval

34. Oven Type:

electrical static

35. Oven power electric [kW]:

6.30

36. Oven size:

GN 2/1

37. Type of internal part of the appliance 1 (eg oven):

Electric

38. Type of internal part of the appliance 2 (eg oven):

Static

39. Gasket:

Yes

40. Maximum temperature of the inner chamber [°C]:

300

41. Minimum temperature of the inner chamber [°C]:

50